

Network Line Card Testing Using the TDS3000B DPO



COMPUTING
COMMUNICATIONS
VIDEO

▶ Designed to Maximize Test Throughput

The need for high-speed testing in telecommunication equipment manufacturing is critical, due to increased line card channel count and higher production demands.

While telecommunication network data rates continue to climb with the emergence of high-speed electrical interfaces such as STM-1E and STS-3 and optical interfaces such as OC-192, the “bread and butter” of today’s network access equipment still lies in low to medium data rate electrical interfaces such as ITU-T G.703 E1/E3, ANSI T1.102 DS1/DS3, and custom variations of these standards. An STM-1E (156 Mb) signal contains enough information to service 63 E1 (2 Mb) drops in an Add/Drop multiplexer. Low to medium data rates are also used heavily for wireless access to the network through radio link equipment.

With the combination of increased channel count and demand for higher production, the need for high-speed testing in telecommunication equipment manufacturing has become even more critical. The TDS3000B with the Telecom Mask Test (TDS3TMT) application module is designed to maximize test throughput for single and multiple channel digital interface line cards.

The TDS3000B Advantage

The TDS3000B digital phosphor oscilloscope (DPO) Series brings important capabilities to the task of pass/fail line card testing. The TDS3000B’s DPO waveform throughput is thousands of waveforms per second – much faster than traditional digital storage oscilloscopes (DSOs). Mask testing is performed as a hardware “compare” of the waveform to the mask standard. This combination of DPO waveform throughput and hardware-assisted mask testing results in breakthrough test speeds for mask testing on single and multiple channel devices (e.g., 2, 4, 8, 16, ... 63 channel line cards). All four channels on a TDS3000B DPO can be used to simultaneously perform a pass/fail test on a multi-channel device.

Network Line Card Testing using the TDS3000B DPO

► Application Note

Line Card Testing Example: Throughput = Shippable Dollars

Overall manufacturing test throughput is dependent on many factors. Figure 1 shows a typical line card test setup using an oscilloscope, a channel multiplexer, and a GPIB control unit. Figure 2 shows a flow diagram of the GPIB test program. The total test time for one line card is the time it takes the controller to complete the test loop N number of times, where N is the number of outputs on the line card under test.

For a 63-line add/drop multiplexer test, every second spent in the loop adds a minute to the total test time, which adds up quickly. An analysis of each program segment reveals where time may be saved:

- T1 – Here all the initialization must occur as well as an initial “Autoset to Mask” for the first channel. Note that for some applications, this autoset must move inside the loop.
- T2 – If automated, this represents very little time. However, if operator intervention is required, a significant penalty will be incurred.
- T3 – This time is usually much larger than T2. Typical time waiting for the system to stabilize is 500 ms to 1 s.
- T4 – Here is where the performance of the test instrument comes to bear. The TDS3000B Series combines DPO acquisition rates with hardware-assisted mask testing which results in test time several times faster than traditional digital oscilloscopes.

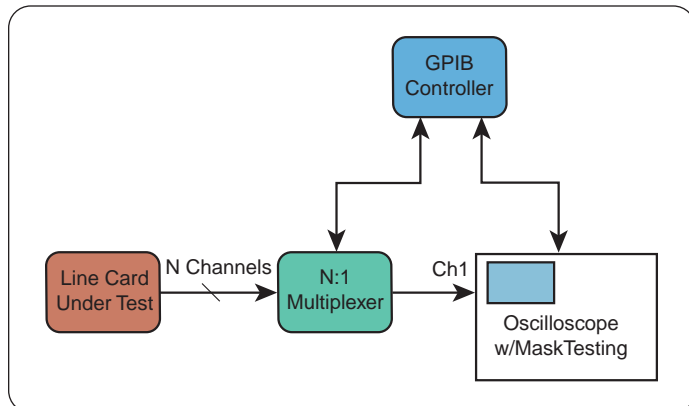

► **Figure 1.** Typical test setup for telecom line card testing.

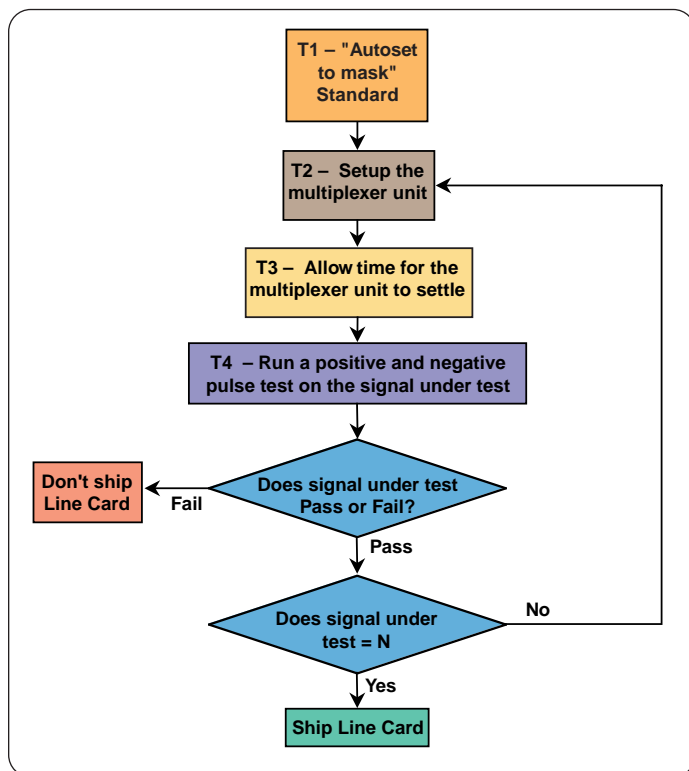

► **Figure 2.** Test program for GPIB controller.

Maximized Throughput Using Multi-channel Testing

The TDS3000B DPO allows you to use hardware-assisted mask testing on multiple channels simultaneously. Figure 3 shows an alternative test setup to Figure 1 using all four channels of a TDS3054B to perform testing. Its *ALT TRIG* mode allows the TDS3054B to trigger on and test each channel, even if the signals are not synchronous in nature.

This configuration significantly reduces the number of times the program loops shown in Figure 2 need to be executed, thus, increasing throughput by a factor of four.

Figure 4 shows an example of a Failed ITU-T E1 Coax test. Because all four channels are turned on, all four channels are part of the test. Multiple channel testing occurs automatically by turning on more than one channel. The E1 mask is displayed in blue and all four channels are compared to the mask. The readout shows that Ch4 failed 26 waveforms out of the specified 1000 for the test. Mask failures are captured and highlighted in the mask region. In this case, the operator can easily tell that the signal on Ch4 failed the test because the highlighted waveforms appear in a bright green color, the same color as the Ch4 selection button on the TDS3000B front panel.

Setting up the TDS3000B to Perform Pass/Fail Mask Testing

Depending on the environment, a test procedure can be fully automated (as shown in the previous example), semi-automated, or manually executed. The TDS3000B DPO's *Telecom QUICKMENU* (see menu area of Figure 4) provides quick and easy access to commonly used telecom testing functions. You display the Telecom QUICKMENU by simply pressing the QUICKMENU button on the TDS3000B front panel and then pressing the MENU button until MENU > Telecom is displayed. Once the Telecom QUICKMENU is selected, it becomes the default QuickMenu whenever the front-panel QUICKMENU button is pressed.

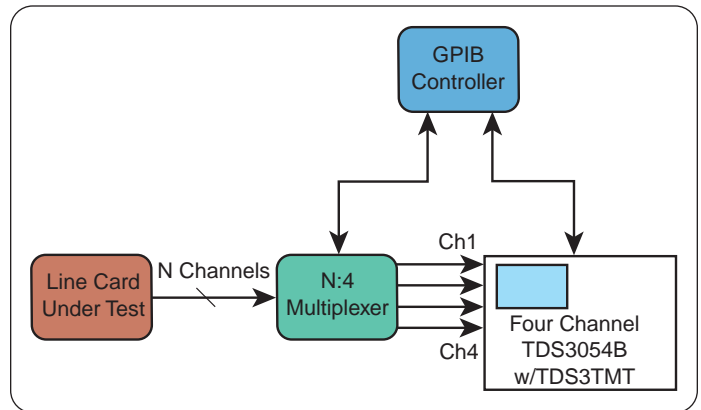

► **Figure 3.** System design for maximized throughput using TDS3000B multi-channel testing.

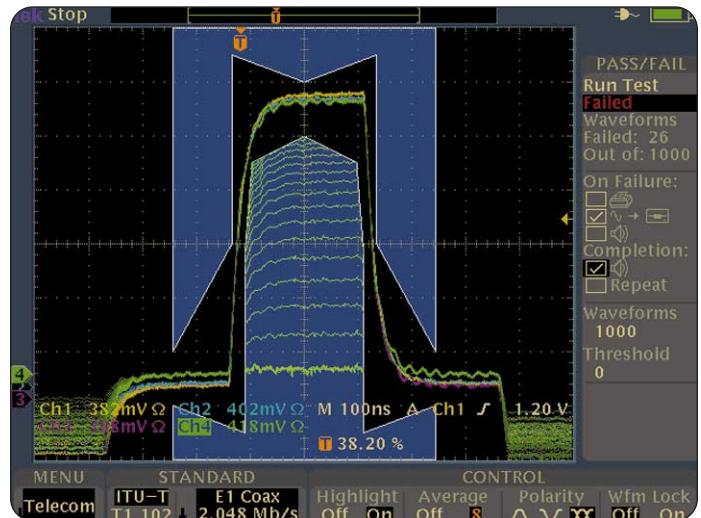

► **Figure 4.** Mask failures are captured and highlighted. The TDS3000B Telecom QUICKMENU puts all the commonly used telecom testing functions on a single menu.

Network Line Card Testing using the TDS3000B DPO

► Application Note

The Telecom QUICKMENU has three sections: STANDARD; CONTROL; and PASS/FAIL.

The **STANDARD** section of the Telecom QUICKMENU lets you select the desired standard mask. In this case ITU-T E1 Coax (2.048 Mb/s) is selected.

The **CONTROL** section of the Telecom QUICKMENU lets you set the behavior of the test. There are four control settings:

- **Highlight** identifies portions of the waveform that violate the mask.
- **Average** controls the number of acquired waveforms to be averaged together during the test.
- **Polarity** selects whether the positive pulse, negative pulse, or both are tested. If both is selected, the instrument will test the positive pulse then automatically invert the signal and test the negative pulse.
- **Wfm Lock** locks the waveform and mask so that they can be positioned together on the screen. Wfm Lock is very useful when you want to use the front-panel ZOOM button to get a closer look at a mask failure.

The **PASS/FAIL** section of the Telecom QUICKMENU is designed to allow the user to enter how many Waveforms constitute a test and the Threshold number of failed waveforms that constitutes a failed test. This portion of the menu is also used to display test results, select “action on failure,” and select “action when complete”. These are all useful features in automated, semi-automated, and manual pass/fail testing.

Other functions that are part of the TDS3TMT package but are not in the Telecom QUICKMENU reside in the “System > Apps” menu. To access this menu, press the front-panel UTILITY button, press the “System” button until it reads “System > Apps;” then press the “Module” button until it reads “Module > Telecom”. This menu provides access to all the functions of the TDS3TMT application module.

Editing the Mask

Often in manufacturing, you need to use a mask that is either a variation of a standard or is a manufacturer’s proprietary mask. In the TDS3000B, a custom mask is referred to as the “User Mask”, and is identified by the .MSK extension (e.g., <filename>.MSK). The User Mask can be transferred over the GPIB bus, over a network connection, or saved and recalled from a floppy disk.

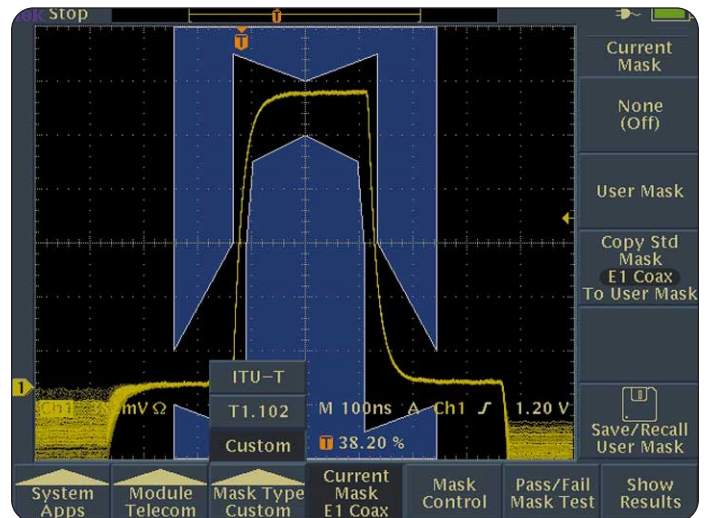

► **Figure 5.** Selecting the Custom Mask when a standard mask needs to be edited.

To create or edit a User Mask file, use WaveStar™ for Oscilloscopes software (WSTRO) Version 2.3. WaveStar for Oscilloscopes provides an easy Windows®-based interface for editing masks for use on the TDS3000B. To create a custom .MSK file from the E1 Coax standard, do the following:

1. Go to the “Module > Telecom” menu as described in the previous section. Figure 5 shows this menu.
2. Press the “Mask Type” button until the readout says “Mask Type > Custom.” The custom mask menu will appear.
3. Press the “Copy Std Mask E1 Coax To User Mask” button to define the current mask as the User Mask.
4. The User Mask can now be transferred to WaveStar for Oscilloscopes over the GPIB bus, network, or via floppy.
5. Use WaveStar for Oscilloscopes’ mask editing tool to edit the .MSK file.
6. Load the new User Mask by transferring the edited .MSK file to the User Mask location in the TDS3000B.
7. Return to the “Module > Telecom > Custom > Current Mask” menu and select “User Mask” as the Current Mask.

► **Table 1. Selecting the right oscilloscope for the standards being tested**

Telecom Standard		Data Rate (Mb/s)	Recommended Oscilloscopes						Optional Input Adapter	Custom Masks	Connectivity	
ITU-T G.703	ANSI T1.102		TDS3012B	TDS3014B	TDS3032B	TDS3034B	TDS3052B	TDS3054B			GPIB	LAN
DS1	DS1	1.544	X	X	X	X	X	X	Use AFTDS	Use WSTRO	Use TDS3GV	Built-in*
E1	DS1A	2.048	X	X	X	X	X	X				
-	DS1C	3.152	X	X	X	X	X	X				
DS2	DS2	6.312	X	X	X	X	X	X	Use AMT75			
E2	-	8.448	X	X	X	X	X	X				
E3	-	34.368	-	-	X	X	X	X				
DS3	DS3	44.736	-	-	X	X	X	X	Use AMT75	Internal and WSTRO	Standard	Use AD007
-	STS1	51.840	Use TDS700D Series with Opt. 2C									
E4	DS4	139.264										
STM1-E	STS3	155.520										

Selecting the Right Tools for the Job

Tektronix provides a complete portfolio of oscilloscope solutions for the telecommunications manufacturing test environment. The TDS3000B Series DPO is ideal for Pass/Fail testing up to DS3 (44.736 Mb/s) electrical tributary data rates. The TDS700D Series DPO can also test these low-to-medium rate standards, as well as high-speed electrical and optical standards up to OC-12 (622 Mb/s). Table 1 shows the recommended oscilloscope and optional input adapters for each telecommunication standard. Wavestar for Oscilloscopes software (WSTRO) Version 2.3 provides a Windows-based tool for creating and editing masks on the TDS3000B as well as other TDS oscilloscopes. Wavestar can also be used as a host for transferring masks from one Tektronix oscilloscope to another. For instance, if a mask is created on the TDS700D on the design bench, it can be transferred into WaveStar. This file can then be edited further or transferred to the TDS3000B oscilloscope using a floppy disk, the GPIB bus (using TDS3GV), or the local area network using the built-in Ethernet interface.

Conclusion

Pass/Fail testing on low to medium data rate line cards is still critical for today's telecom equipment manufacturers. As channel count and volume of line cards increases, throughput becomes more important to ensure product quality. The TDS3000B DPO provides breakthrough test speeds for single and multiple channel testing, making it ideal for manufacturing-test applications. The easy-to-use Telecom QUICKMENU makes instrument setup a snap. WaveStar for Oscilloscopes software (WSTRO) provides easy mask editing for the TDS3000B in a Windows environment. Automated and semi-automated testing with the TDS3000B can be performed using the built-in Ethernet port. Tektronix also provides a full portfolio of oscilloscopes for telecommunications standards compliance testing.

Network Line Card Testing using the TDS3000B DPO

► Application Note



- **The TDS3EM Communications Module** provides local area network printing and programming via an Ethernet port.
- **The TDS3GV Communications Module** provides full talk/listen modes with control of all modes, settings, and measurements.



- **The AFTDS Differential Signal Adapter** and the **AMT75 75Ω Adapter** provide an effective means for 50Ω terminated instruments to connect to and analyze differential and high-speed electrical communications signals as well as video signals.

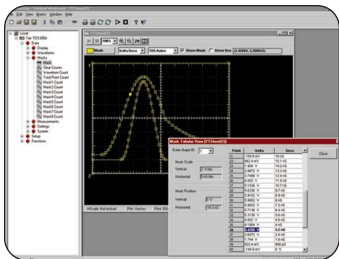

- **Wavestar™ for Oscilloscopes Software (WSTRO)** is a Windows 95/98/NT 4.0 application to capture, analyze, document, and control data.

www.tektronix.com

ASEAN Countries (65) 356-3900

Australia & New Zealand 61 (2) 9888-0100

**Austria, Central Eastern Europe,
Greece, Turkey, Malta & Cyprus** +43 2236 8092 0

Belgium +32 (2) 715 89 70

Brazil and South America 55 (11) 3741-8360

Canada 1 (800) 661-5625

Denmark +45 (44) 850 700

Finland +358 (9) 4783 400

France & North Africa +33 1 69 86 81 81

Germany + 49 (221) 94 77 400

Hong Kong (852) 2585-6688

India (91) 80-2275577

Italy +39 (2) 25086 501

Japan (Sony/Tektronix Corporation) 81 (3) 3448-3111

Mexico, Central America, & Caribbean 52 (5) 666-6333

The Netherlands +31 23 56 95555

Norway +47 22 07 07 00

People's Republic of China 86 (10) 6235 1230

Republic of Korea 82 (2) 528-5299

South Africa (27 11) 254 8360

Spain & Portugal +34 91 372 6000

Sweden +46 8 477 65 00

Switzerland +41 (41) 729 36 40

Taiwan 886 (2) 2722-9622

United Kingdom & Eire +44 (0)1344 392000

USA 1 (800) 426-2200

For other areas, contact: Tektronix, Inc. at 1 (503) 627-1924

For Further Information

Tektronix maintains a comprehensive, constantly expanding collection of application notes, technical briefs and other resources to help engineers working on the cutting edge of technology.

Please visit "Resources For You" at www.tektronix.com

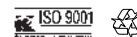

Copyright © 2001, Tektronix, Inc. All rights reserved. Tektronix products are covered by U.S. and foreign patents, issued and pending. Information in this publication supersedes that in all previously published material. Specification and price change privileges reserved. TEKTRONIX and TEK are registered trademarks of Tektronix, Inc. All other trade names referenced are the service marks, trademarks or registered trademarks of their respective companies.

0301 TD/PG 3GW-13606-1